

Runergy PV Modules

Installation and Maintenance Manual

2023 Ver 2.0

www.runergy-solar.com

This manual contains important safety instructions for the Photovoltaic Modules (hereafter referred to as "Modules") of Runergy New Energy (hereafter referred to as Runergy). Installers should follow all safety precautions described in this guide as well as local codes when installing Modules.

Installing photovoltaic systems requires specialized skills and knowledge. Installation should only be performed by qualified personnel.

Before installing a photovoltaic system, installers should familiarize themselves with its mechanical and electrical requirements. Keep this guide in a safe place for future reference and in case of sale or disposal of the Modules.

For any questions, please contact our Global Quality and Customer Service department for further information.

1. INTRODUCTION

Thank you for choosing RUNERGY PV modules!

This Installation Manual contains essential information for electrical and mechanical installation that you must know before handling and installing Runergy PV Modules. This Manual also contains safety information you need to be familiar with. All the information described in this Manual is the intellectual property of Runergy and is based on the technologies and experience that have been acquired and accumulated by Runergy.

This Manual does not constitute a warranty, expressed or implied. Runergy does not assume responsibility and expressly disclaims liability for loss, damage, or expense arising out of or in any way connected with installation, operation, use or maintenance of Modules. No responsibility is assumed by Runergy for any infringement of patents or other rights of third parties that may result from use of Modules. Runergy reserves the right to make changes to the product, specifications or installation manual without prior notice.

Failure to comply with the requirements listed in this manual will invalidate the Limited Warranty for Modules as provided by Runergy at the same time of sale to the direct customer. Additional recommendations are provided to enhance safety practices and performance results. Please provide a copy of this manual to the PV system owner for their reference, and inform them of all relevant aspects of safety, operation, and maintenance.

2. CODES AND REGULATIONS

The mechanical and electrical installation of PV systems should be performed in accordance with all applicable codes, including electrical codes, building codes and electric utility interconnection requirements. Such requirements may vary for mounting location. Requirements may also vary with system voltage, and for DC or AC application. Contact local authorities for governing regulations.

3. GENERAL

3.1. Product Identification

3.1.1. Nameplate:

Nameplate describes the product type, peak power, Max. power voltage, open circuit voltage, short circuit current, all as measured under standard test conditions; certifications mark, the maximum system voltage etc.

3.1.2. Barcode:

Each individual module has a unique serial number. The serial number has 20 digits. The 6th and the 7th digits are the year code, the 8th and the 9th digits are the month code, and the 10th and the 11th digits are the day code. For example, H0101220627000401133 means the module was assembled and tested on 2022.06.27. Each module has only one bar code. It is permanently attached to the interior of the module and is visible from the top front of the module. This barcode is inserted prior to laminating.



Typical serial number barcode label

3.2. Conventional safety requirement

Runergy PV Modules are designed to meet the requirements of IEC 61215 and IEC 61730, application class II. Modules rated for use in this application class may be used in system greater than 50V DC or 240W, where general contact access is anticipated.

When modules are mounted on rooftops, the roof must have a fire-resistant covering suitable for this application. Rooftop PV systems should only be installed on rooftops capable of handling the additional weighted load of PV system components, including modules, and have a complete analysis of the structure performed by a certified building specialist or engineer.

For your safety, do not attempt to work on a rooftop until safety precautions have been identified and taken, including without limitation fall protection measures, ladders or stairways, and personal protective equipment.

For your safety, do not install or handle modules under adverse conditions, including without limitation strong or gusty winds, and wet or frosted roof surfaces.

3.3. Electrical performance safety

Photovoltaic modules can produce DC electricity when exposed to light and therefore can produce an electrical shock. DC voltage of 30 Volts or higher is potentially lethal.

Modules produce voltage even when they are not connected to an electrical circuit or load. Please use insulated tools and appropriately rated rubber gloves when working with modules in sunlight.

Modules have no on/off switch. Modules can be rendered inoperative only by removing them from sunlight, or by fully covering them with cloth, cardboard, or other completely opaque material.

In order to avoid arcs and electrical shock, please do not disconnect electrical connections under load. Faulty connections can also result in arcs and electrical shock. So please keep connectors dry and clean, and ensure that they are in proper working condition. Never insert metal objects into the connector, or modify them in any way in order to secure an electrical connection.

Also, in order to avoid the sand or water vapor entering which may cause a safety issue with the connection, the modules need to be installed and connected to the combiner box once they are taken out from the carton box; keep the connectors dry and clean during the installation, if the modules are not be installed within a week, rubber connector covers shall be added as a protective measure. Note that pollution from sand, dust and water will result in arcs and electrical shock of connectors. We suggest that customers add rubber connector covers as protection method especially in areas with heavy dust or seaside areas with higher salinity or serious polluted areas.

Reflection from snow or water can increase sunlight and therefore boost current and power. In addition, colder temperature can substantially increase voltage and power. If the glass or other material is damaged, please wear personal protection equipment and separate the module from the circuit.

Work only under dry conditions, and use only dry tools. Do not handle modules when they are wet unless wearing appropriate protective equipment. If you need to clean the modules, please follow the cleaning requirements mentioned in the manual.

Installation must be carried out under the guidance of a qualified electrician.

3.4. Operating safety

Do not open the package of Runergy modules until they are ready to be installed during transportation and storing.

At the same time please protect the package against exposure to damage. Secure pallets from falling over. Do not exceed the maximum height of pallets to be stacked, as indicated on the pallet packaging. Store pallets in a ventilated, rain-proof and dry location until the Modules are ready to be unpacked. Please unpack the package of Runergy modules according to "Runergy PV Modules Unpacking Instruction" or similar documents.

Do not lift the modules by grasping the module's junction box or electrical leads in any condition.

Do not stand or step on the Modules.

Do not drop the Modules on another Module.

Do not place any heavy objects on the Modules to avoid glass breakage.

Be cautious when setting the modules down on to a surface, especially on the corner of the modules. Inappropriate transport and installation may break the modules.

Do not attempt to disassemble the modules, and do not remove any attached nameplates or components from the

modules.

Do not apply paint or adhesive to the modules' top surface.

Do not drill holes in the frame. This may compromise the frame strength and cause corrosion of the frame.

Do not scratch the anodized coating of the frame (except for grounding connection). It may cause corrosion of the frame or compromise the frame strength.

Do not attempt to repair the modules with damaged glass.

The scrapped modules shall be recovered and disposed by the qualified institution.

In dry areas, modules are easily affected by static electricity during installation. The installation personnel should wear anti-static assembly to ensure that the equipment and installation personnel are not affected or hurt by static electricity.

3.5. Fire safety

Consult your local authority for guidelines and requirements for building or structural fire safety. Runergy PV modules have been designed in accordance with IEC61730 standard.

For roof installations, modules should be mounted over a fire-resistant covering suitable for this application, with adequate ventilation between the module backside and the mounting surface.

Roof constructions and installations may affect the fire safety of the building. Improper installation may create hazards in the event of a fire.

Use appropriate components such as fuses, circuit breaker and grounding connector as requires by local authority. Do not use modules where flammable gasses may be generated.

Runergy modules have not been tested for explosion protection. Please consult local regulations whether the modules can be used or not.

3.6. Wiring Method

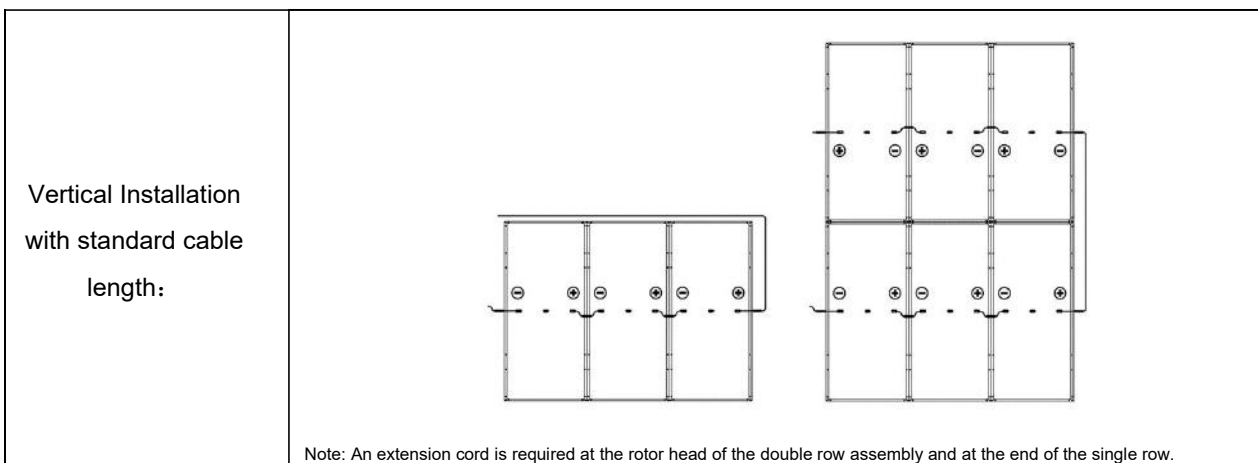

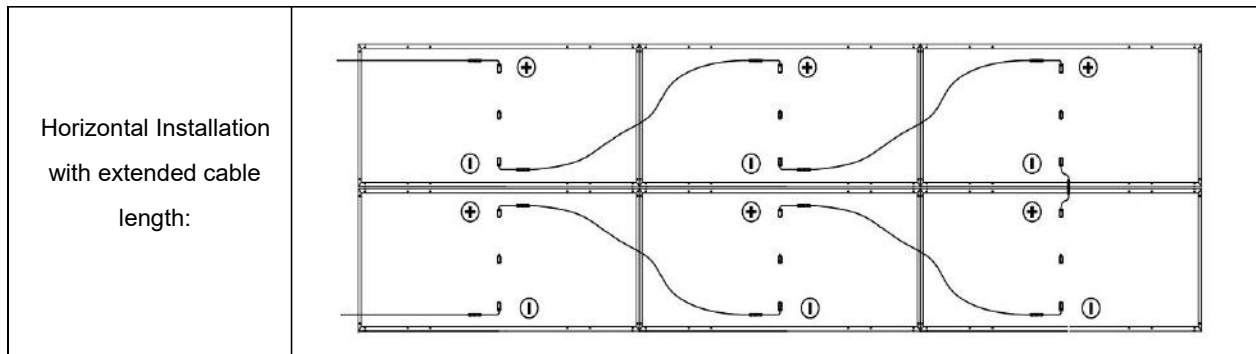

4. INSTALLATION

4.1. Installation position and working environment

Runergy PV modules are intended for use in terrestrial applications, no outer space use. Do not use mirrors or other magnifiers to concentrate sunlight onto the modules.

Modules must be mounted on appropriate mounting structures positioned on suitable buildings, the ground, or other structures suitable for modules (eg, carports, building facades or PV trackers).

Modules must not be installed in locations where they could be submerged in water.

The recommended ambient temperature should be within -40°C (-40°F) to 40°C (104°F). The temperature limits are defined as the monthly average high and low of the installation site. The limit operating temperature should be -40°C (-40°F) and 85°C (185°F).

Ensure modules are not subject to wind or snow loads exceeding the maximum permissible loads.

The modules should be installed in a location where there's no shading throughout the year. Ensure there's no obstacle to block light near the installation site.

Lightning protection is recommended for PV systems that are to be installed in locations with high probability of lightning strikes.

Do not use modules near equipment or in locations where flammable gas may be generated or collected.

Modules cannot be installed or used in extreme areas or weather conditions, and highly corrosive areas should be considered carefully.

Please adopt appropriate measures to ensure the performance and safety of the modules when they are installed or operated in areas with heavy snow, extremely cold, strong wind, or near an island or desert that is prone to produce salty fog, or near water.

Runergy PV modules have passed salt-mist test based on IEC 61701, evidence for testing is available on request, but galvanic corrosion can occur between the aluminum frame of the modules and mounting or grounding hardware if such hardware is comprised of dissimilar metals. Runergy PV Modules can be installed at seaside locations 50m to 500m from the sea, but the components should be protected against corrosion.

Modules cannot be applied for some special requirements, e.g., for buildings, marine and vehicle applications.

Please refer to local law and regulations for details.

4.2. Tilt angle selection

The tilt angle of the modules is measured between the surface of the modules and a horizontal ground surface. The modules generate maximum power output when it faces the sun directly.

In the northern hemisphere, modules should typically face south, and in the southern hemisphere, modules should typically face north.

For detailed information regarding the best installation angle, please refer to standard solar photovoltaic installation guides or consult a reputable solar installer or systems integrator.

Dust building up on the surface of the modules can impair module performance. Runergy recommends installing the modules with a tilt angle of at least 10 degrees, making it easier for dust to be washed off by rain.

5. MECHANICAL INSTALLATION

5.1. Conventional requirements

Ensure the installation method and supporting system of modules is strong enough to withstand all the load conditions. The Installer must provide this guarantee. The installation supporting system must be tested by third-party organization with the analysis ability of Static Mechanical, according to the local national or international standards.

The modules mounting structure must be made of durable, corrosion-resistant and UV-resistant material.

Modules must be securely attached to the mounting structure.

In regions with heavy snowfall in winter, select the height of the mounting system so that the lowest edge of the modules is not covered by snow for any length of time. In addition, ensure that the lowest portion of the modules is placed high enough so that it is not shaded by plants or trees or damaged by flying sand.

When the modules are supported parallel to the surface of a building wall or roof, a minimum clearance of 10cm between the modules frame and the surface of the wall or the roof is required to allow air to circulate behind the modules and to prevent wiring damage.

Do not attempt to drill holes in the glass surface and the frames of the modules as this will void the warranty.

Before installing modules on a roof, ensure that the roof construction is suitable. In addition, any roof penetration required to mount the modules must be properly sealed to prevent leaks.

Observe the linear thermal expansion of the module frames (the recommended minimum distance between two modules is 10 mm). The module frames will warp at low temperature.

Avoid the frame receiving the lateral tension and pressure, which may damage the frame and glass.

Modules have been certified for a maximum static load on the back side of 2400Pa (i.e., wind load) and a maximum static load on the front side of either 2400Pa or 5400Pa (i.e., wind and snow load), depending on the modules type (please refer to the following installation methods for details).

The mounting method must not result in the direct contact of dissimilar metals with the aluminum frame of the modules as it will result in galvanic corrosion. IEC 60950 standard recommends metal combinations not exceed an electrochemical potential difference of 0.6 Volts.

Runergy PV modules can be mounted in landscape or portrait orientation. For the bifacial modules, in order to maintain the energy yield of module's rear side, the distance between the bottom of modules and the

roof or ground surface is recommended to be at least 1m.

5.2. Installation methods

Modules can be installed to the racks by clamps or hooks. Modules must be installed according to the following examples and recommendation. If Modules are not mounted according to these instructions, please consult Runergy Solar in advance and it must be approved by Runergy Solar, otherwise this act may damage the Modules and void the warranty.

5.2.1. Modules installed with clamp (For framed bifacial PERC mono double-glass modules)

A. Module should be attached on a supporting structure rail by metal clamps.

It is recommended to use the clamps under the following condition or parts approved by Runergy:

Width: $\geq 50\text{mm}$; Thickness: $\geq 3\text{mm}$; Material: Aluminum Alloy, 6063-T5; Bolt: Stainless Steel M8; Nut: Stainless Steel M8; Washer: Stainless Steel M8

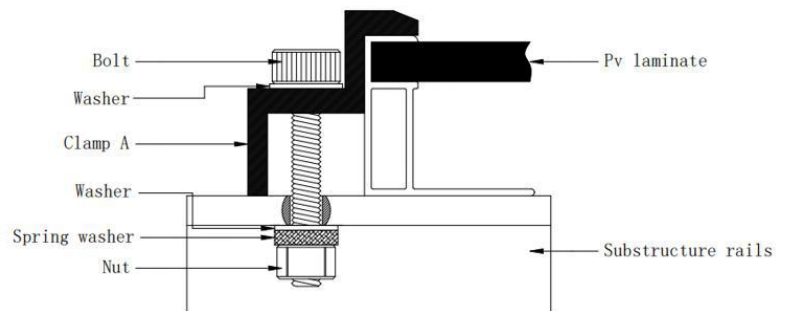
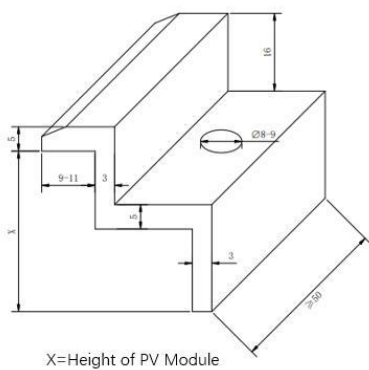

Clamp A

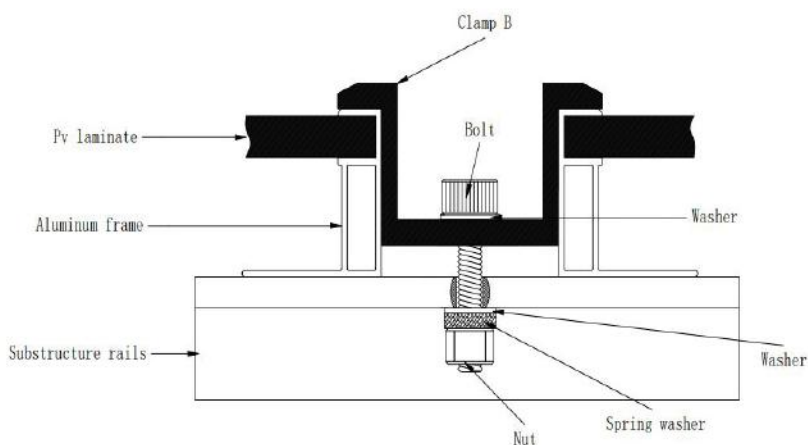

Clamp B

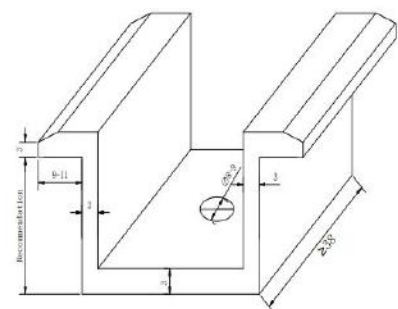

Figure 1: Mounting details (Units: mm)

B. Recommended bolt torque range: 18N.m to 24N.m.

C. The modules clamps should not contact the front glass or deform the frame in any way. Avoid shading effects from the module's clamps. Drainage holes on the modules frame should not be closed or obscured by the clamps. Besides, two or more screws or two full threads of a single screw shall engage the metal.

5.2.2. Modules installed with mounting hole

Modules should be bolted to support structures through mounting holes located in the frame's back flanges. Refer to what is shown in Figure 2 (Mounting Details).

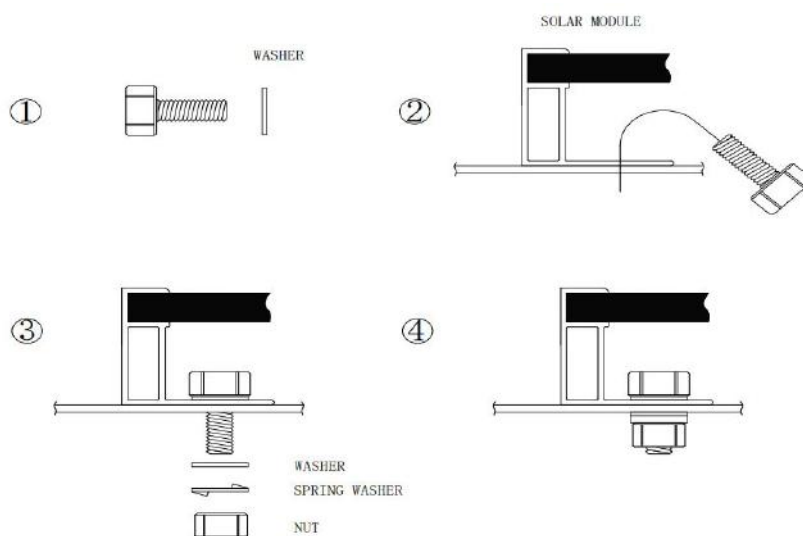

Figure 2: Mounting Details

For your reference, please use the components specified below:

	1. Bolt	2. Washer	3. Spring washer	4. Nut
Material	Q235B/SUS304	Q235B/SUS304	Q235B/SUS304	Q235B/SUS304
Size& length	M8/M6*16mm	M8/M6	M8/M6	M8/M6
Remark	Recommended torque is between 12N.m to 16N.m for M8, 8N.m to 12N.m for M6			

5.3. Installation position and corresponding static loads

The low/normal level of load condition is applicable to the installation in most of environmental conditions: the maximum static load on the back of the modules is 2400Pa (i.e. wind load), and the maximum static load on the front of modules is 2400Pa (i.e. wind and snow load).

The high level of load condition is applicable to the installation in harsher environmental conditions such as storm, heavy snow, etc. The maximum static load on the back of the modules is 2400Pa (i.e., wind load), and the maximum

static load on the front of modules is 5400Pa (i.e., wind and snow load), depending on the pressure level that it would endure according to IEC standard.

For the dynamic loads, such as wind, the safety factor needs to be increased by 3 times. It means that the maximum dynamic load is 800Pa when the wind speed is less than 130 km/h.

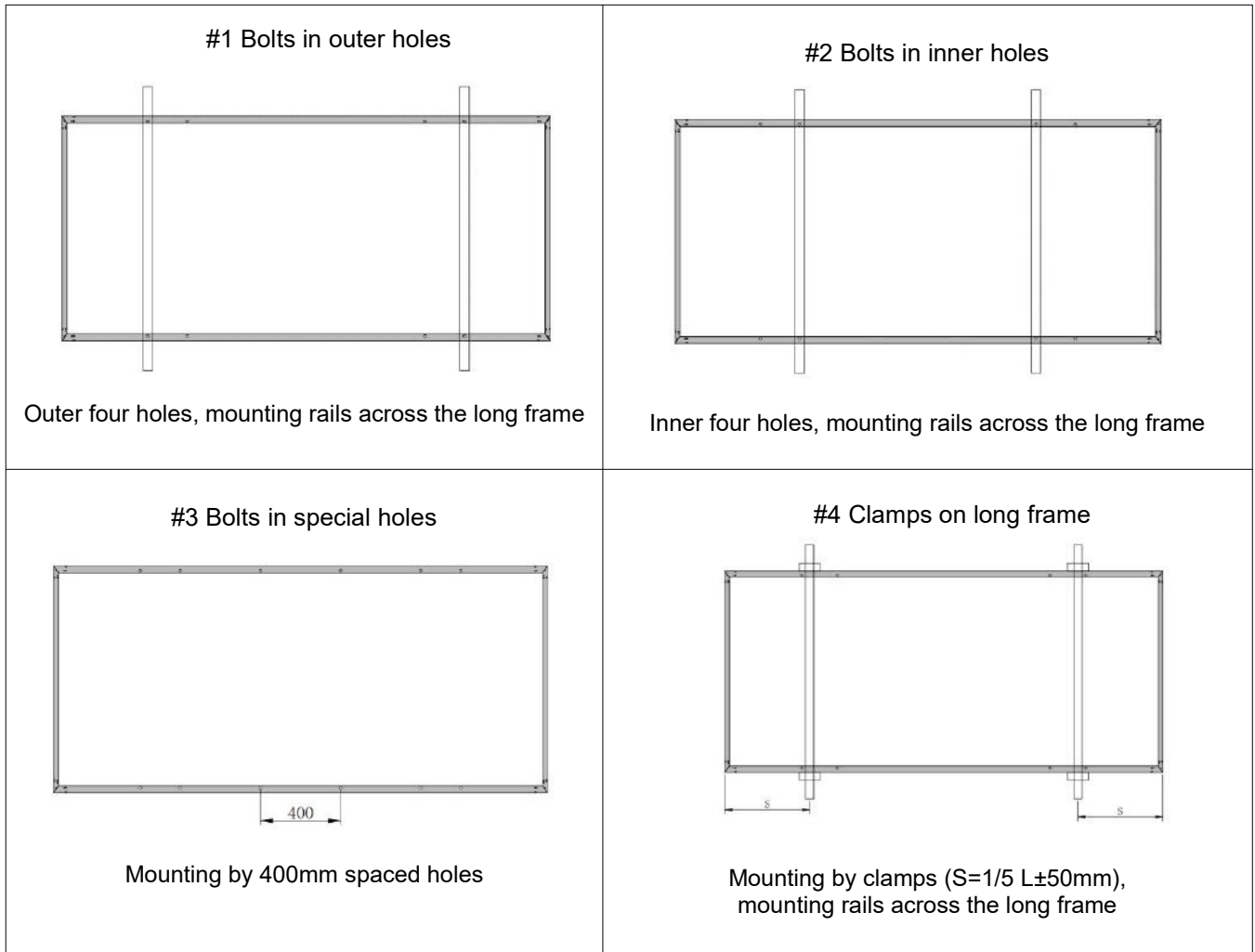

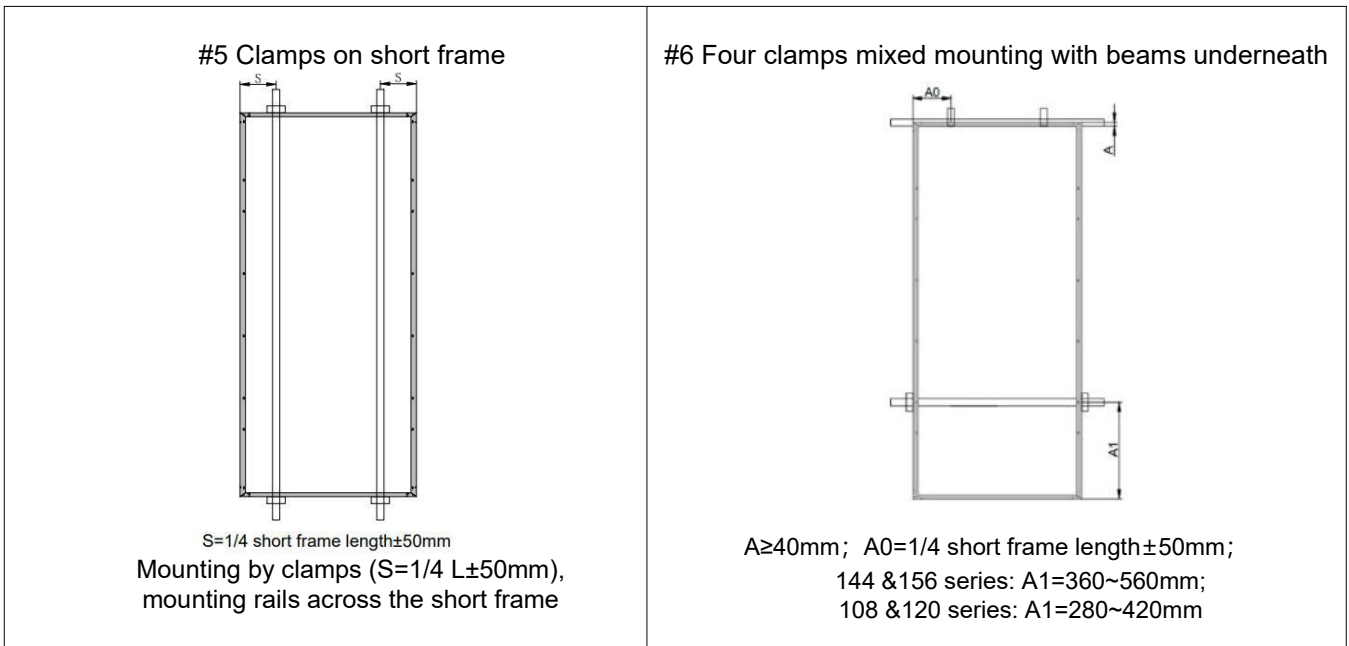

Installation method		#1 Bolts in outer holes	#2 Bolts in inner holes	#3 Bolts in special holes	#4 Clamps on long frame	#5 Clamps on short frame	#6 Clamps mixed mounting	
Framed bifacial double-glass modules	with 1.6mm&1.6mm glass	HY-DH108N8	+5400pa/-2400pa	---	---	+5400pa/-2400pa	---	
		HY-DH156P8 HY-DH156N8	+5400pa/-2400pa	---	---	+5400pa/-2400pa	---	
		HY-DH144P8 HY-DH144N8	+5400pa/-2400pa	+3600pa/-2400pa	+2400pa/-2400pa	+5400pa/-2400pa	+2400pa/-800pa	+2400pa/-2400pa
	with 2.0mm&2.0mm glass	HY-DH132P8 HY-DH132N8	+5400pa/-2400pa	+3600pa/-2400pa	+2400pa/-2400pa	+5400pa/-2400pa	+2400pa/-1200pa	---
		HY-DH120P8 HY-DH120N8(B)	+5400pa/-2400pa	+3600pa/-2400pa	---	+5400pa/-2400pa	+2400pa/-1600pa	+2400pa/-2400pa
		HY-DH108P8 HY-DH108N8(B)	+5400pa/-2400pa	+3600pa/-2400pa	---	+5400pa/-2400pa	+2400pa/-1600pa	+2400pa/-2400pa
		HY-WH144P8 HY-WH144N8	+5400pa/-2400pa	+3600pa/-2400pa	+2400pa/-2400pa	+5400pa/-2400pa	---	---
Single-Glass Modules	with 3.2mm front glass	HY-WH132P8 HY-WH132N8	+5400pa/-2400pa	+3600pa/-2400pa	+2400pa/-2400pa	+5400pa/-2400pa	---	
		HY-WH120P8 HY-WH120N8	+5400pa/-2400pa	+3600pa/-2400pa	---	+5400pa/-2400pa	+1200pa/-1200pa	---
		HY-WH108P8 HY-WH108N8(B)	+5400pa/-2400pa	+3600pa/-2400pa	---	+5400pa/-2400pa	---	---

Figure 3: Installation Position and Corresponding Load Relation

6. ELECTRICAL INSTALLATION

6.1. Electrical property

The rated electrical characteristics, I_{sc} is within +/- 4% and V_{oc} is within +/- 3% of measured values at Standard Test Conditions, but for the P_{max} , it is within +/-3%. Standard Test Conditions: 1000W/m² Irradiance, 25°C Cell Temperature and 1.5 AM.

Under normal conditions, the photovoltaic modules may experience conditions that produce more current and/or voltage than reported at Standard Test Conditions. Accordingly, the values of short circuit current, I_{sc} , and open

circuit voltage, V_{oc} , marked on modules should be multiplied by a factor of 1.25 when determining component voltage ratings, conductor capacities, fusing sizes, and size of controls connected to the module output.

Voltages are additive when modules are connected directly in series, and modules currents are additive when modules are connected directly in parallel, as illustrated in Figure 4. Modules with different electrical characteristics must not be connected directly in series.

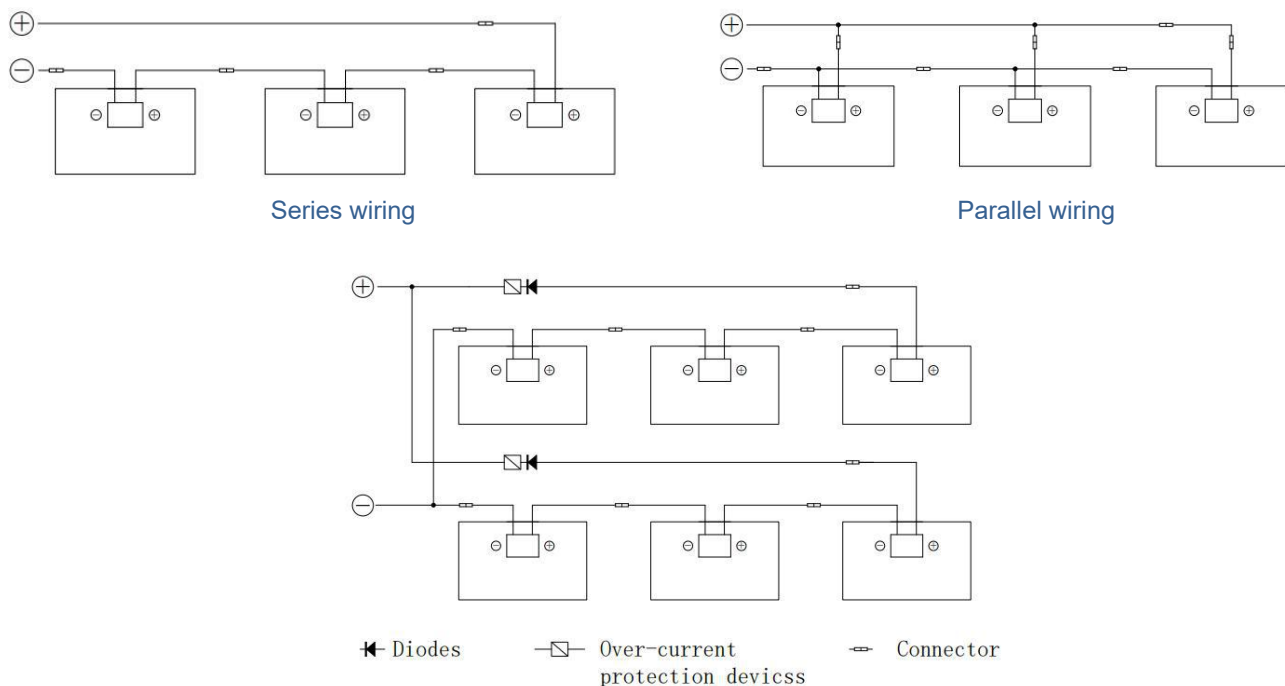

Figure 4: Electrical diagrams of series and parallel wiring

The maximum number of modules that can be connected in a series string must be calculated in accordance with applicable regulations in such a way that the specified maximum system voltage (The maximum system voltage of Runergy Modules is DC 1500V) of the modules and all other electrical DC components will not be exceeded in open-circuit operation at the lowest temperature expected at the PV system location.

Correction factor for the open-circuit voltage can be calculated based on the following formula: $C_{voc} = 1 - \beta_{voc} * (25 - T)$.

T is the lowest expected ambient temperature at the system location. β (%/°C) is the temperature coefficient of the selected module V_{oc} (refer to corresponding datasheet).

An appropriately rated over-current protection device must be used when the reverse current could exceed the value of the maximum fuse rating of the modules. An overcurrent protection device is required for each series string if more than two series strings are connected in parallel, in Figure 4.

6.2. Cables and Wiring

These junction boxes have been designed to be easily interconnected in series for their well-connected cable and the connector with IP68 protection grade. Each module has two single-conductor wires, one positive and one negative, which are pre-wired inside the junction box. The connectors at the opposite end of these wires allow easy series

connection of adjacent modules by firmly inserting the positive connector of a module into the negative connector of an adjacent module until the connector is fully locked.

Use field wiring with suitable cross-sectional areas that are approved for use at the maximum short-circuit current of the modules. Runergy recommends installers use only sunlight resistant cables qualified for direct current (DC) wiring in PV systems. The minimum wire size should be 4 mm² (12AWG).

Rating Required Minimum Field Wiring

Testing standard	Wire size	Temperature rating
EN 50618: 2014	4 mm ²	-40 °C to +90 °C

Cables should be fixed to the mounting structure in such a way that mechanical damage of the cable and/or the modules is avoided. Do not apply stress to the cables. The minimum cables bending radius should not be less than 8 times of the cable diameter. Any cable damage caused by bending too much or cable management system is not covered under Runergy's warranty. For fixing, use appropriate means, such as sunlight resistant cable ties and/or wire management clips specifically designed to attach to the module frame. While the cables are sunlight resistant and waterproof, where possible, avoid direct sunlight exposure and water immersion of the cables. Cable arrangement must comply with local laws and regulations.

6.3. Connectors

Keep connectors dry and dean, and ensure that connector caps are hand tight before connecting the modules. Do not attempt making an electrical connection with wet, soiled, or otherwise faulty connectors. Avoid sunlight exposure and water immersion of the connectors. Avoid connectors resting on the ground or roof surface.

Faulty connections can result in arcs and electrical shock. Check that all electrical connections are securely fastened. Make sure that all locking connectors are fully engaged and locked. Connector interconnect must reach the corresponding IP protection level, so as to achieve the electrical security.

Do not contact organic solvents and other corrosive materials in connector connection and the using environment, such as alcohol, gasoline, pesticides, herbicides, etc. Please consult RUNERGY for details. Otherwise, Runergy will not be responsible for connector cracking caused by this aspect. Two examples of incorrect usage are listed below:



The unlock method of connectors is different according to local laws and regulations, please pay attention.

6.4. bypass diodes

The junction boxes used with Runergy modules contain bypass diodes wired in parallel with the PV cell strings. In the case of partial shading, the diodes bypass the current generated by the non-shaded cells, thereby limiting modules heating and performance losses. Bypass diodes are not over-current protection devices.

In the event of a known or suspected diode failure, installers or maintenance providers should contact Runergy. Never attempt to open the junction box by yourself.

Please pay attention to guard against inductive lightning, backflow and wrong connection.

7. GROUNDING

The grounding is only used on the framed modules.

Runergy modules use an oxidized aluminum frame to resist corrosion. The frame of modules must be connected to the equipment grounding conductor to prevent thunder and static hurt.

The grounding device should fully contact with the inside of the aluminum alloy, and penetrate the surface of the frame oxidation film.

Please don't drill any additional grounding hole on the frame of the modules, otherwise Runergy expressly disclaim liability for voiding the warranty.

Besides equipment grounding, to reduce PID risk, negative system grounding is also recommended by Runergy. Failure to comply with this requirement maybe reduce the performance of the system.

The grounding method should not result in the direct contact of dissimilar metals with the aluminum frame of the modules that will result in galvanic corrosion. IEC 60950 standard recommends metal combinations not exceed an electrochemical potential difference of 0.6 Volts.

The frame rails have pre-drilled holes marked with a grounding sign. These holes should be used for grounding purposes and must not be used for mounting the modules.

The following grounding methods are available.

7.1. Grounding by using grounding bolt

There is a grounding hole with 4.2mm diameter on the edge side closer to the middle of the modules. The middle line of the grounding mark is overlapped with the grounding hole, and the direction is same as the longer frame.

The grounding between modules must be approved by a qualified electrician. The grounding device must be produced by a qualified electrical manufacturer. The recommended torque value is 2.3 N.m. 12 AWG copper wire can be used as the equipment grounding conductor in conjunction with the grounding bolt. The copper wire should not be squashed during the installation.

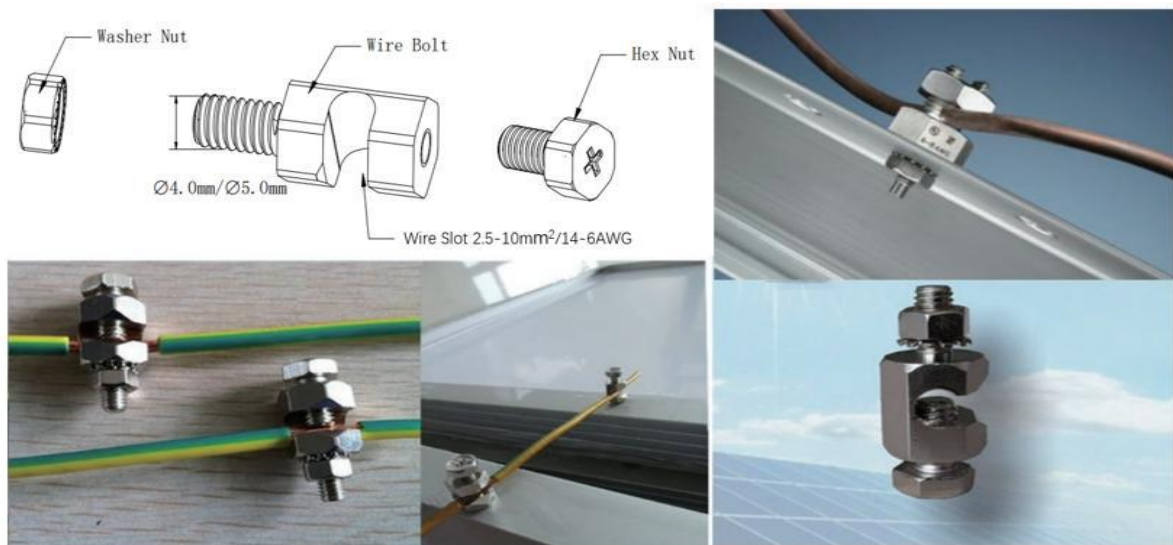

Figure 5: Installation method

7.2. Grounding by using unused mounting hole

The existing mounting holes which have not been used can be used for grounding.

- Direct the grounding clamp to the mounting hole on the frame. Thread the grounding clamp and the frame with grounding bolt.
- Put the toothed gasket into the other side, then tighten and lock the nut. The recommended torque of locking the nut is 2.0N.m~2.2N.m.
- Thread the grounding clamp with grounding wire. The material and size of grounding wire should meet relevant requirements of the national, regional and local code, law and standard.
- Finish the mounting with tightening the binding bolt of the grounding wire.

7.3. Additional third-party grounding devices

Runergy PV modules can be grounded using third party grounding devices so long as they are certified for grounding modules and the devices are installed according to the manufacturer's specified instructions.

8. OPERATION AND MAINTENANCE

It is required to perform regular inspection and maintenance of the Modules, especially within warranty scope. It is the user's responsibility to report to the supplier regarding the damages found within 2 weeks.

8.1. Cleaning

The dust accumulated on the front transparent substrate may reduce the power output, and may even cause regional hot-spot effect. Industrial effluents or bird drops may be a serious case, and the extent of the severity depends on the transparency of the foreign objects. It's usually not dangerous for the accumulated dust to reduce the sunshine,

because the light intensity is still homogeneous and the power reduction usually is not obvious.

When Modules are operational, there may exist environmental factors that may distinctly reduce the power output. Runergy advises that there should be no obstructed object over the Module' s surface at any time.

When cleaning, pay attention to wear suitable clothes and insulated gloves. Check the integrity of the PV modules before and after cleaning, to ensure that there is no damage, loose joints, etc. to prevent the risk of electric shock.

The cleaning frequency depends on the accumulating velocity of the fouling. In many instances the front substrate is cleaned with rain, and we can decrease the cleaning frequency. It is recommended to wipe the glass surface with wet sponge or soft cloth. Please do not clean the glass with cleaning agent which contains acid or alkali. Please refer to "cleaning manual" for specific contents.

It is recommended that the time of cleaning should be in the early morning or late evening, when the light intensity is weak or the temperature is relatively low, to reduce the risk of potential electric shock or burns.

8.2. The visual inspection of the modules

Inspect the Modules visually to find if there are appearance defects, pay more attention to the following situation:

- Whether the glass is broken;
- Corrosion along the cells' bus-bar. The corrosion is caused by the dampness infiltrated into the Modules when the surface encapsulation material is damaged during the installation or transportation;
- If there is burning vestige on the backsheet;
- Whether the fixing screws between PV modules are loose or damaged; whether the PV connector connection is tight, and make timely adjustment or repair;
- Whether the grounding is good;
- Whether there are obstacles and foreign objects covering the surface of PV modules.

8.3. Inspection of the connector and the cables

It' s recommended to implement the following preventive maintenance every 6 months:

- Check the encapsulation of the connector with the cable.
- Check the sealing gel of the junction box to ensure it is not cracked.

9. CONTACT US

Company: Jiangsu Runergy New Energy Technology Co., Ltd.

Manufacturer Address: Room 1-101, 58 Xiangjiang Road, Economic Development Zone, Yancheng City, Jiangsu Province, 224000, China

Email: service-inform@runergy.cn

10. PRODUCT SUPPLEMENT

The installation manual is applicable for module types below. The module types are subject to changes without prior notice due to continuous product innovation, research and development.

Name	Dimension (mm)
HY-DH108N8(B)	1722*1134*30/35
HY-DH108P8	1722*1134*30/35
HY-WH108P8	1722*1134*30/35
HY-WH108N8(B)	1722*1134*30/35
HY-DH120N8(B)	1908*1134*30/35
HY-DH120P8	1908*1134*30/35
HY-WH120P8	1908*1134*30/35
HY-WH120N8	1908*1134*30/35
HY-DH132N8	2094*1134*30/35
HY-DH132P8	2094*1134*30/35
HY-WH132P8	2094*1134*30/35
HY-WH132N8	2094*1134*30/35
HY-DH144N8	2278*1134*30/35
HY-DH144P8	2278*1134*30/35
HY-WH144P8	2278*1134*30/35
HY-WH144N8	2278*1134*30/35
HY-DH156N8	2465*1134*35
HY-DH156P8	2465*1134*35